

BINOS
2017



Solutions & Products

1. BINOS

2. Decades of Experience

3. Production Lines

1. Ultra Flex - Insulation ^{*NEW*}
2. Ultra Line ^{*NEW*}
3. Ultra PB ^{*NEW*}
4. MDF | HDF Line
5. Facade Production

4. Forming & Pressing Solutions

1. Ultra Press ^{*NEW*}
2. Calender/Mende Press
3. Ultra Former
4. Wind Forming with Patented Roller Bed
5. Fibre Turbine
6. BINOS Scraper ^{*NEW*}
7. BINOS Scalper

5. Service & Engineering

BINOS

BINOS is offering single machines but also complete solutions. It develops unique and customized technologies for new and existing plants for the wood working industry and for the production of thermoplastics.

BINOS is the specialist in mixing and dissolving processes, in forming as well as in pressing solutions. Improving and developing all kind of panel surfaces to further increase your quality is the passionate field.

BINOS cannot influence your raw material, energy or personnel costs but **WE CAN** influence the overall efficiency to decrease your total production costs. Because we are aiming at giving high value to our customers. So BINOS technologies are designed for increasing quality, decreasing costs and having high plant availabilities due to less maintenance services and easier handling.

Make valuable panels from wood waste or agrifibre

BINOS production lines are also available for other raw materials such as agrifibre products. BINOS processes waste into raw materials that can be formed on BINOS production lines into useful and valuable products.

Companies are facing high investment risks nowadays. BINOS has taken up this challenge and has improved technologies and systems which are profitable despite all risks. Our plant solutions have an average Return on Investment of about 5 years. Our single technologies for wood-based panel products can achieve Return of Investment of under 1 year.

Decades of Experience

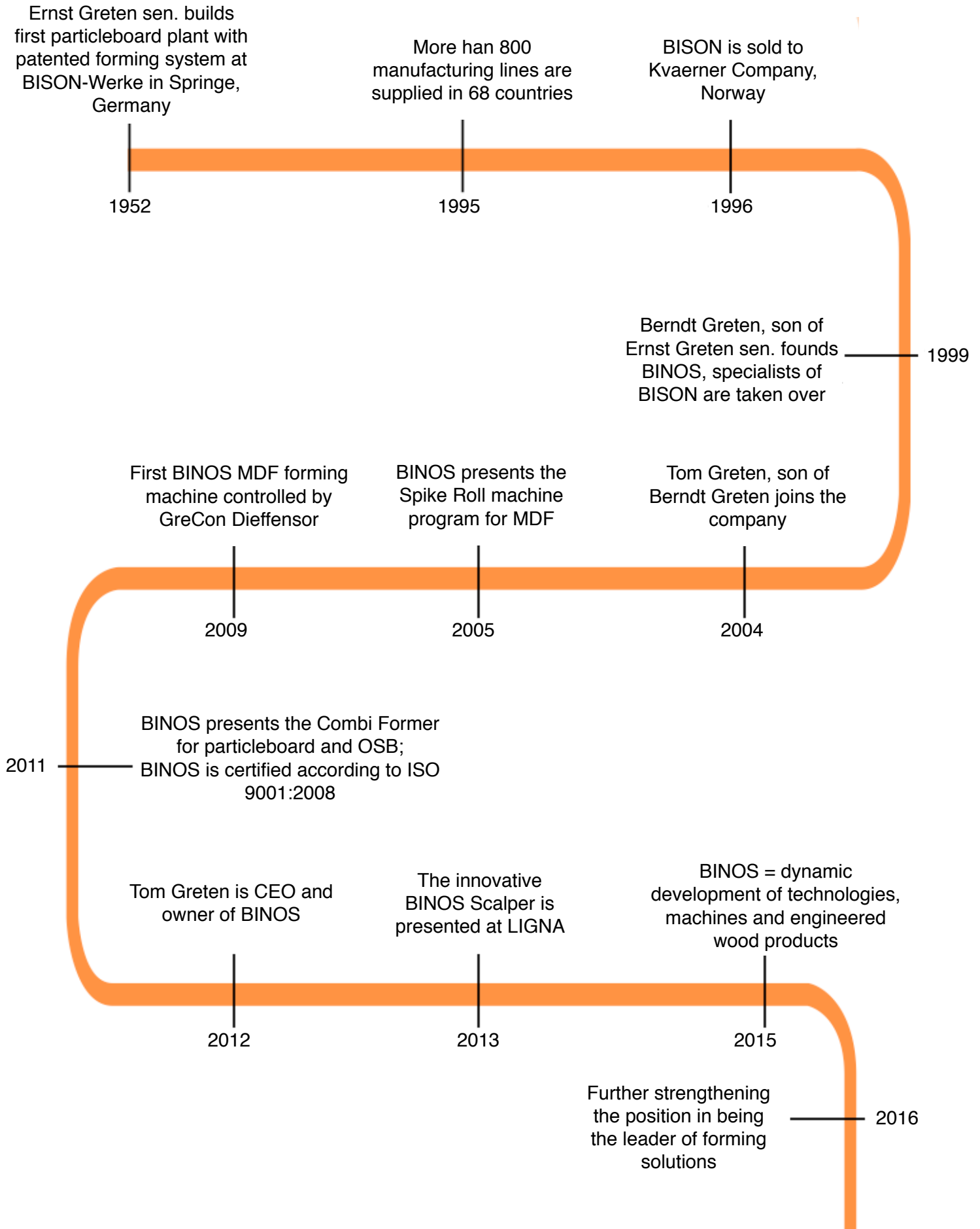

PRODUCTION LINES

Ultra Flex ^{*NEW*}

Perfectly combined BINOS technologies such as **Fibre Turbine** and **Ultra Former** enable the production of best insulation boards which differentiate themselves from existing insulation materials.

SUBSTANTIAL SAVINGS

Spreading process is much more efficient as usual processes; savings of machine park is possible; the payback period is thus shorter.

MOST EFFICIENT SPREADING RESULT

Best fibre distribution, already in the beginning of a production process.

Benefits of the BINOS Ultra Flex production line

- Best agglomeration of fibres and spreading accuracy
- More insulation with less material usage
- Improved Lambda value
- Competitive production costs
- High-quality insulation boards
- Lean production
- Efficient process
- Low maintenance effort
- Energy savings

Ultra Line ^{*NEW*}

Discover the Ultimate Combination

New Forming and Pressing Approach at BINOS

BINOS is the specialist in forming and pressing processes. With „Ultra Line“ we summarize our Ultra Forming and Ultra Pressing technology which can be applied on the one hand for the production of homogeneous vinyl floors and on the other hand with similar equipment for the production of ultra thin MDF I HDF or insulation boards.

The innovative forming approach enables optimized spreading results for homogeneous products. The upgraded pressing approach at BINOS consists of the „Calender/Mende press“ which is especially designed for ultra thin MDF I HDF boards and the „Ultra Press“ for homogeneous vinyl floors.

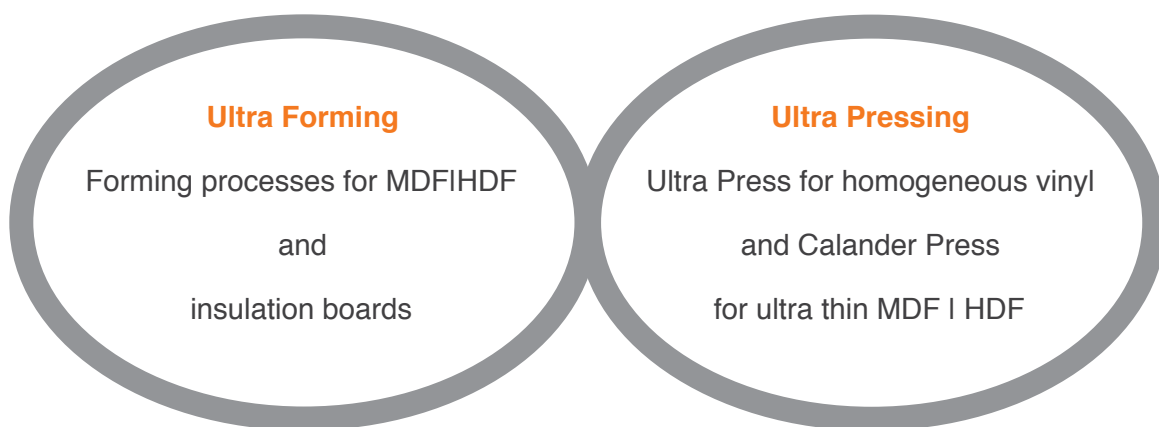

Benefits of the BINOS Ultra Line

- Consistently high quality
- Significant material savings and fast ROI
- Less wear-and-tear-parts
- Lean production
- Repeatability of products

Ultra PB

Particleboard Production Line

Furniture marketers get independent

BINOS has developed a turnkey particleboard production line for furniture marketers.

Particleboards need to be strong but also thin and flexible at the same time. As furniture have more lightweight designs, it is essential that the used material meet these requirements. Furniture marketers are now able to react to fast changing conditions and adapt the used material immediately. The included technologies are covering especially the forming and pressing processes. The BINOS Wind Forming machine optimizes the geometry of the core layer of the boards. As a pressing system it is possible to install a BINOS Calender/Mende press for the production of ultra thin particleboards.



Particleboard made with date palm

Benefits of the BINOS Ultra PB

- Optimized product development of your furniture
- Decrease of transportation costs
- Diverse capacities possible
- Individual products
- For immediate use in your furniture production, lean and efficient production
- Flexible production
- High performance

MDF | HDF Production Line

MDF | HDF panels are used primarily for the furniture production or the flooring segment. With the BINOS production line you are able to produce diverse board thicknesses under most efficient production conditions.

Our production line is perfectly adapted to your special needs.

BINOS offers turnkey production lines and has mainly specialized in forming solutions and pressing systems for MDF | HDF production.

Benefits of MDF | HDF panels produced on BINOS production line

- Closed and homogeneous surface
- Ready for further process – ready for direct coating
- Less paint and coating consumption
- Fine fibres
- Board thickness ranges from 0.5 to 8 mm
- Homogeneous area weight distribution

Benefits of BINOS MDF | HDF production line

- Calender/Mende press enables high pressure distribution and quick increase of temperature
- Low investment costs
- Low maintenance costs
- Easy handling

Facade Production Line

Customers are able to produce extravagant cladding with the BINOS Facade production line which meets highest design demands. The BINOS structural enhancer enables the production of individual structural boards to adapt on design trends.

Standard daily capacities are available from 25 m³, 50 m³, 100 m³ and 200 m³. Board thicknesses with smooth surfaces are available from 8 to 40 mm and structured surfaces are available from 12 to 24 mm.

Benefits of facade boards produced on BINOS production line

- Versatile construction material
- Production of diverse board surfaces: smooth, structured, lacquered
- Ecological product
- Durable product

Benefits of BINOS Facade production line

- BINOS structure enhancer for individual designs
- Smart finishing process
- Repeatability of products
- Consistent high quality
- Energy-saving production
- High degree of flexibility
- Ability to change application process (e.g. for flooring, wet rooms, acoustics)



Facade Production Line



FORMING & PRESSING SOLUTIONS



Ultra Press ^{*NEW*}

The Ultra Pressing Approach for homogeneous vinyl floors

Explore the innovative pressing technology for the production of homogeneous vinyl flooring. The BINOS Ultra Press creates a homogeneous surface by isobaric pressure over width and length. That means that a continuous material composition can be achieved over the whole thickness. Explore the consistent high quality of structure, colour and surface – made for the high design requirements of your customers!

Our press can be adapted to your needs and desired application area. Accordingly, isochoric pressing is also possible or a combination of both pressing methods.

Benefits of the BINOS Ultra Press

- Energy saving press system with low maintenance
- Isobaric pressure distribution
- Adaptation to your needs and applications

Benefits of vinyl floors produced with BINOS Ultra Press

- Variety of designs
- Low material input
- Homogeneous material composition, colour and structure
- Diverse material thicknesses with constant material characteristics

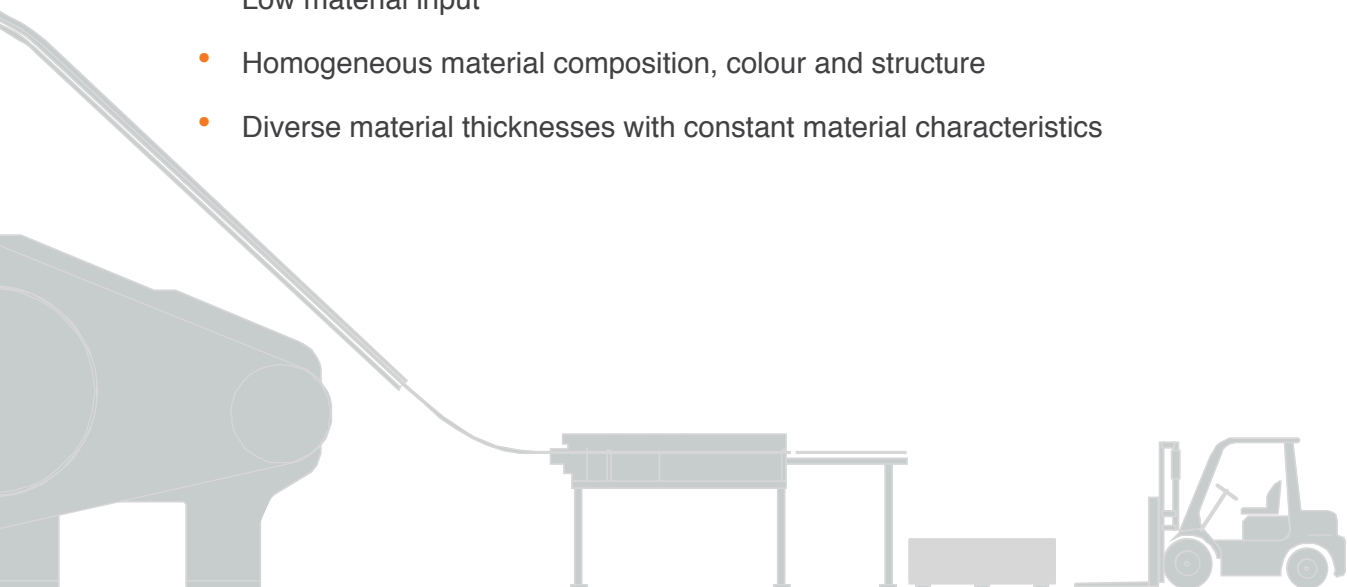

Calender/Mende Press

The Ultra Pressing Approach for the production of MDF | HDF and particleboards

The Ultra Pressing Approach consists among others of the Calender/Mende Press for MDF | HDF and particleboards. The Calender/Mende Press enables fast production speed due to high pressure distribution and fast increase of temperature in the board.

The Calender/Mende Press is especially suitable for the production of ultra thin boards which are mainly used for furniture production. It further enables direct lamination and coating so production processes can be reduced which has a significant impact on the production costs.

Benefits of the BINOS Calander Press

- Fast production speed
- Easy handling
- Boards ready for further process
- Space efficient design
- Smooth production running is enabled, adapted to efficient Forming – Pressing – Finishing processes
- Energy efficiency
- Proven technology



Ultra Former

The basis for high-quality boards and satisfied end customers

Carefully matched components are leading to results that increase the quality of your board tremendously. The BINOS Ultra Former provides the most homogeneous spreading process in the market. It allows an excellent density distribution and an optimized surface. The Ultra Former concept will be adapted depending on the application field and on your planned investment efforts. So there is no strict machine layout - BINOS offers “the” solution in considering the overall process.

Originally designed for the fibre board production further developments were initiated. The Ultra Former can be applied for MDF | HDF board production as well as for the production of insulation boards.

Benefits of the BINOS Ultra Former

- Smart machine design
- Efficient use of material
- Efficient and homogeneous material distribution
- Homogeneous board characteristics
- Depending on requirements static or dynamic manipulation of the area weight by separate traces – extensive upgrade options



Wind Forming with Patented Roller Bed

BINOS Wind Forming is used in particleboard plants to optimize the geometry of the core layer of the boards. Due to same handling, this application (just without the patented roller bed) can be easily added to existing cement bonded particleboard plants.

A ventilator regulates the air so exactly that the chips are separated by sizes automatically. The oversized chips are spread mainly in the core layer. A smooth mat is the result. This spreading accuracy leads to a higher panel quality; especially with respect to the transverse tensile strength.

Yet another advantage: The patented roller bed of BINOS. To further optimize the spreading accuracy BINOS is implementing spreading rolls underneath the wind forming chambers in the area of the air registers - and this also as an upgrade to your existing plant.

HOMOGENEOUS SPREADING RESULTS

Homogeneous transition between the middle and top layer is created when small chips are separated accurately and automatically from oversized chips.

INCREASED SPREADING ACCURACY

Improved spreading accuracy across the spreading width – improved panel quality.

Benefits of the BINOS Wind Forming

- Improved panel tensile strength
- Reduced consumption of raw materials
- Reduced gross density with consistently high quality at the same time
- Improved spreading accuracy across the spreading width with a homogeneous core layer



Fibre Turbine

Must-Have for improved Dissolved Fibres

The Fibre Turbine dissolves agglomerated fibres to a homogenised flow of single fibres. This machine is able to mix fibres with any different kind of fibres, powder or granulate.

Homogeneous mixtures of these materials are the basis for the most modern composite materials of organic and inorganic fibres. Fibre products can be recycled into single fibres to reinforce fresh products.

The BINOS Fibre Turbine is available from 0.5 t/h to 60 t/h.

The design and layout of the machine decreases significantly your maintenance and service costs - it is especially interesting for low-risk investments.

Benefits of the BINOS Fibre Turbine

- Dissolving of agglomerated fibres
- Mixing any kind of fibres together
- Preparation of recycled materials
- For any kind of fibres, diverse application areas
- Produces a homogeneous fibre mat

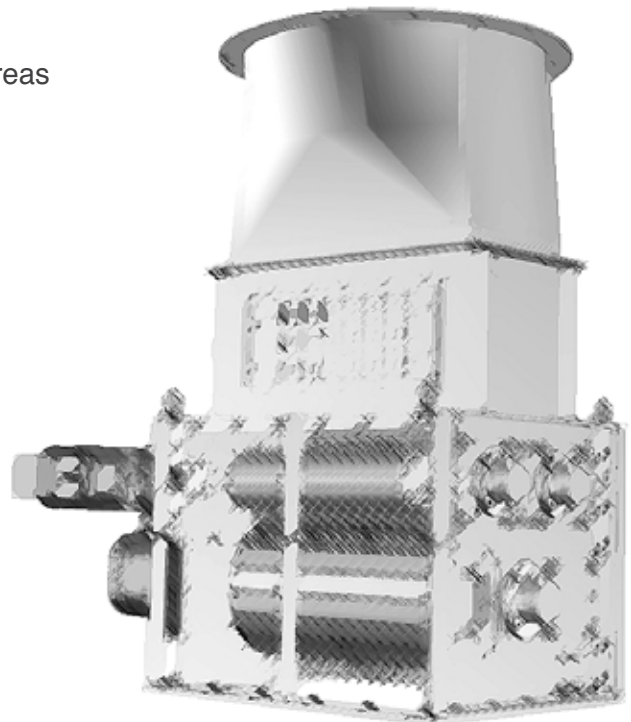

BINOS Scraper ^{*NEW*}

Quality increase of particleboards with less material input

The BINOS Ultra Scraper is the ideal supplement system to achieve high quality with minimum material input.

The material discharge quantity of the dosing bin within the forming machine can be influenced positively during production via the segmented rakes (Ultra Scraper). The single segments which are connected to swinging brackets can be adjusted over the height. The material discharge quantity of the dosing bin can be adapted over the width depending on the requirements of the quality control. Consequently, deviations of the area weight can be reduced to a minimum. Due to the low area weight deviation the gross density of the board can be reduced which has a positive impact on the material usage.

The advantages at one glance

- Material savings
- Reduced area weight deviations
- Productivity increase due to lower tolerances
- Adjustment possibility during production
- Upgrade in existing lines possible
- System automation possible
- Low maintenance
- Low installation costs
- Possibility to level excessively spread material in the edge area

Design Options

- Manually adjusted Scraper
- Motorized adjusted Scraper

BINOS Scalper

Discover the innovative characteristics of our Scalper for an improved weight distribution to gain more homogeneous products.

ROTORS WITH ADJUSTABLE HEIGHT

Each rotor is adjustable in height so single profiles or an area can be cut out of the spread material.

EFFICIENT RECYCLING OF MATERIAL

The removed material can be returned to the production process again – no material loss.

FORMATOR

Combined with the GreCon Dieffensor the BINOS Scalper builds the Formator.

ONLINE MEASUREMENTS

The Formator provides continuous measurements and the position of the single rotors is regulated automatically according to the acquired data.

Benefits of the BINOS Scalper

- Reduction of material costs
- Efficient finishing processes
- Homogeneous board surface
- Positive impact on the area weight
- For MDF | HDF, particleboard and OSB
- Consistent high quality, less non-conforming panels
- Static or dynamic troubleshooting possible, depends on the chosen design

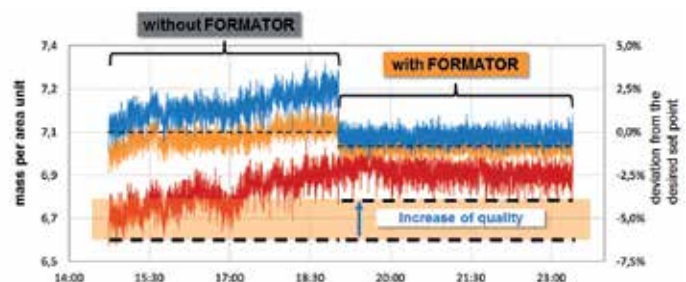

SERVICE & ENGINEERING

Service & Engineering

BINOS offers extensive services to produce perfect panels for all parts of the lifecycle of a plant:

- Consulting
- Project management
- Engineering
- Automation of production processes
- Upgrades & modernisations
- Improvement of product quality
- Development of new products
- Training
- Research & Development
- Technologies
- Assistance in preparing a business plan
- Help in selecting the financing

Supply of spare parts

BINOS supplies spare parts for BISON/BINOS equipment, machines and equipment of other manufacturers, as well as parts manufactured according to customer requirements.



Contract Manufacturing

Due to the mechanical equipment of BINOS, experience and flexibility of the staff BINOS is able to promptly process orders from third parties. The large workshops in Springe offer contract manufacturing in following areas:

- Machining (milling, turning, drilling)
- Burning and welding
- Sheet metal processing
- Lacquering
- Construction of pipelines
- Construction of switch cabinets
- Electrical installation, including cabling, programming and commissioning



Mechanical Installation

- General installation and commissioning of equipment and units
- Balancing shafts, rollers and discs
- Hydraulic and pneumatic control systems

Production workshop

- Space: approx. 10,000 m², divided into three workshops
- Weight per workpiece: up to approx. 50 t
- Loading and unloading within the hall
- Door width: 4.8 m (entry of trucks in the shop)



Welcome to BINOS



BINOS GmbH
Industriestr. 17c
D-31832 Springe

